



# Maintenance-Free Rechargeable Sealed Lead-Acid Battery

## BP5-6



The battery is constructed by plates, separators, safety valves and container. Since the electrolyte is held by a glass-mat separator and plates, the battery can use in any direction and position without leakage.

### PERFORMANCE SPECIFICATIONS

Nominal Voltage(V).....	6 volts(3cells in series)
Nominal Capacity(AH)	
20 hour rate F.V.(1.75V/cell) (250mA to 5.25volts) .....	5.0A.H.
10 hour rate F.V.(1.75V/cell) (475mA to 5.25volts) .....	4.75A.H.
5 hour rate F.V.(1.75V/cell) (850mA to 5.25volts) .....	4.25A.H.
1 hour rate F.V.(1.55V/cell) (3000mA to 4.65volts).....	3.0A.H.
Approximate Weight.....	950g(2.09lbs.)
Terminal	
Standard.....	Type T1
Optional.....	Type T2
Internal Resistance (Fully Charged Battery).....	<13.5m Ω
Maximum Discharge Current For 5 sec.(A).....	75A
Maximum Charge Current(A).....	1.50A
Ambient Temperature	
Charge.....	0°C(32°F)~40°C(104°F)
Discharge.....	-20°C(-4°F)~50°C(122°F)
Storage.....	-20°C(-4°F)~40°C(104°F)
Vibration test:	
Frequency: 16.7HZ	
Amplitude: 4mm	
Vibrate the battery horizontally or vertically for 60 minutes. The battery have no abnormality.	
Case.....	ABS
Dimension(mm/inch)	
Length           ±1.5mm.....	70/2.76
Width           ±1.5mm.....	48/1.89
Container Height ±1.5mm.....	102/4.02
Total Height   ±2mm.....	107/4.21
Application.....	Electronic Toy-Cars. Emergency Lights, Rechargeable Flashlights, UPS, Fans.

### BP5-6 Battery discharge characteristics (25°C/77°F)

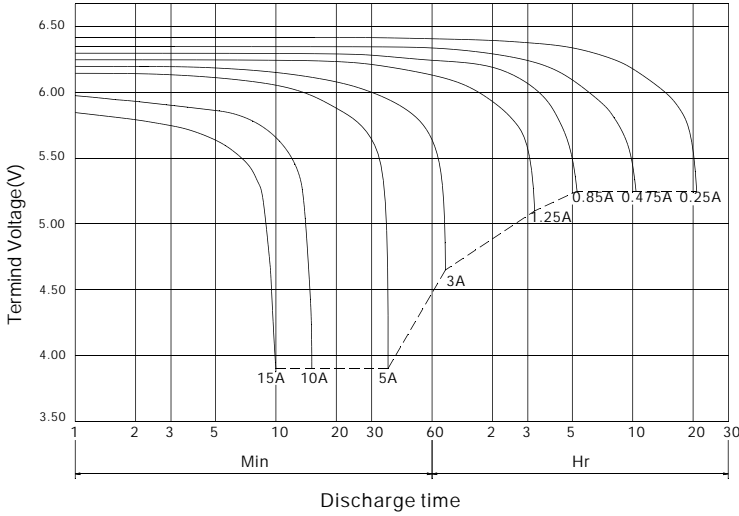

### BATTERY CHARGING CHARACTERISTICS

(Typical example of the charge characteristic for the standby use)

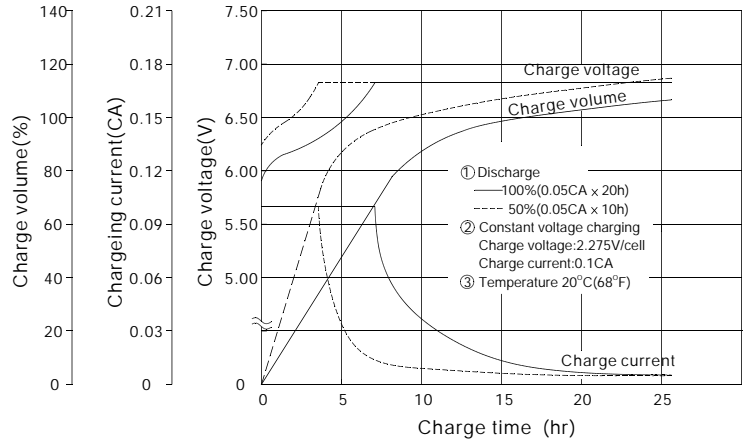

### Charging Procedure

Application	Charging method	Charging Voltage at 20°C (V/cell)	Temperature compensation coefficient of charging voltage (mV/°C/cell)	Max. charging current (CA)	Charging time 0.1CA, 20°C (h)		Temp (°C)
					100% discharge	50% discharge	
For standby power Source	Constant voltage & Constant current charging (with current restriction)	2.25~2.30	-3	0.3	24	20	0-40 (32-104°F)
For cycle service					2.40~2.50	-4	

\*Temperature compensation of charging voltage is not needed, when using the batteries within 5°C to 35°C range.

### Effect of Temperature on Long Term Float Life

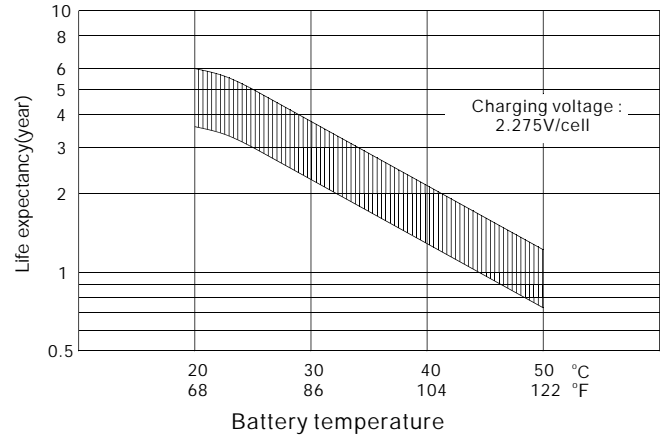

### TERMINAL TYPE

#### OUTER DIMENSIONS

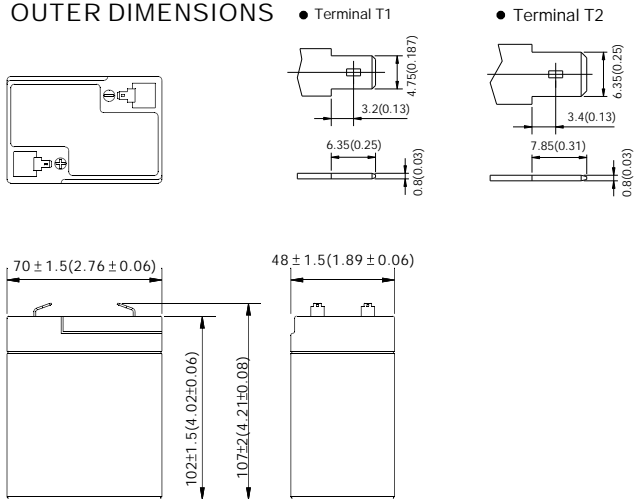

### Constant power discharge characteristics at 25°C/77°F

Final Voltage	Discharge time								
	5Min	10Min	15Min	30Min	1Hr	3Hr	5Hr	10Hr	20Hr
	Battery output power (W)								
5.40V	90.4	66.5	53.3	31.7	18.20	7.29	5.02	2.81	1.47
5.25V	104.6	72.1	55.8	32.9	18.74	7.43	5.10	2.85	1.50
5.10V	111.2	74.7	57.5	33.7	19.08	7.50	5.13	2.86	1.51
4.95V	116.2	76.5	58.8	34.2	19.31	7.55	5.15	2.87	1.51
4.80V	120.0	78.0	60.0	34.5	19.50	7.60	5.16	2.87	1.51

### TERMINAL POSITION

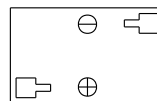

**B.B. BATTERY CO., LTD.** Web Site: <http://www.bb-battery.com>

#### USA :

B&B BATTERY (USA) INC.  
6415 RANDOLPH ST. COMMERCE,  
CA, 90040 U.S.A.  
TEL: 1-323-278-1900 1-800-278-8599  
FAX: 1-323-278-1268

#### CHINA FACTORY:

CHENG DONG TRIAL AREA, HUANG GANG,  
RAOPING GUANG DONG, CHINA, 515700  
TEL: 86-768-7601001-2  
FAX: 86-768-7601469

#### UK:

B & B BATTERY (UK) CO., LTD.  
TEL: 44-161-339-9458  
FAX: 44-161-343-7030

#### HONG KONG:

NATIONAL TRADING LTD.  
TEL: 852-2301-3800  
FAX: 852-2739-1182

#### JAPAN:

B & B BATTERY (JAPAN) CO., LTD.  
TEL: 81-426-256-537  
FAX: 81-426-256-537

#### TAIWAN:

B & B BATTERY CO., LTD.  
TEL: 886-6-5898081-3  
FAX: 886-6-5898087



MH19884

